

How to start the device

Please check the following Before using the device.

I Operating procedure I

- Connect the power cable to the device and press the 'POWER' switch.
- Connect the leads to the patient in accordance with the preparation steps for measuring electrocardiogram.
- Check the setting status for filter, signal size, output speed, channel configuration, rhythm lead, etc., and set them to the desired value if you want to modify them.
- Enter patient information according to the patient information input method.
- If the waveform displayed on the LCD screen is abnormal or there is a lot of noise, take measures according to the 'Measures in case of poor lead connection'.
- If the waveform displayed on the LCD screen is normal, press the 'AUTO' key to record the patient's ECG.
- Press the 'COPY' key to output the same 10-second data input previously, or to output the signal again after processing the modified information.
- Press the 'RHYTHM' key to monitor the ECG signal waveform with a printer instead of on the LCD screen.
- Press the 'ESC' key to stop the operation while printing the printer or saving the ECG.

How to read the eIFU

- 1) <https://www.ebionet.com/operation-manuals/>
- 2) After entering the provided password, you can download the eIFU.

PW: C9Mbh5

Product Configuration

■ Basic composition and accessories

- ① Cardio Q50 / Cardio Q70 Main Body (1EA)
- ② Patient Cable (1EA)
- ③ Limb Electrodes (1SET)
- ④ Chest Electrodes (1SET)
- ⑤ ECG Chart Paper (1EA)
- ⑥ Power Cable (1EA)
- ⑦ ECG Gel (1EA)
- ⑧ ECG Diagnosis Guide (1EA)
- ⑨ Rechargeable Battery (1EA)

■ Optional items

- ① Spiro Handle (1EA)
- ② Spiro Diagnosis Guide (1EA)
- ③ Nose Clip (1EA)
- ④ Mouthpiece Adaptor (1EA)
- ⑤ Handle Dock (1EA)
- ⑥ Disposable Mouthpiece (100EA)
- ⑦ PFT Filter (100EA)
- ⑧ Calibration Syringe [3L] (1EA)

Operation Key

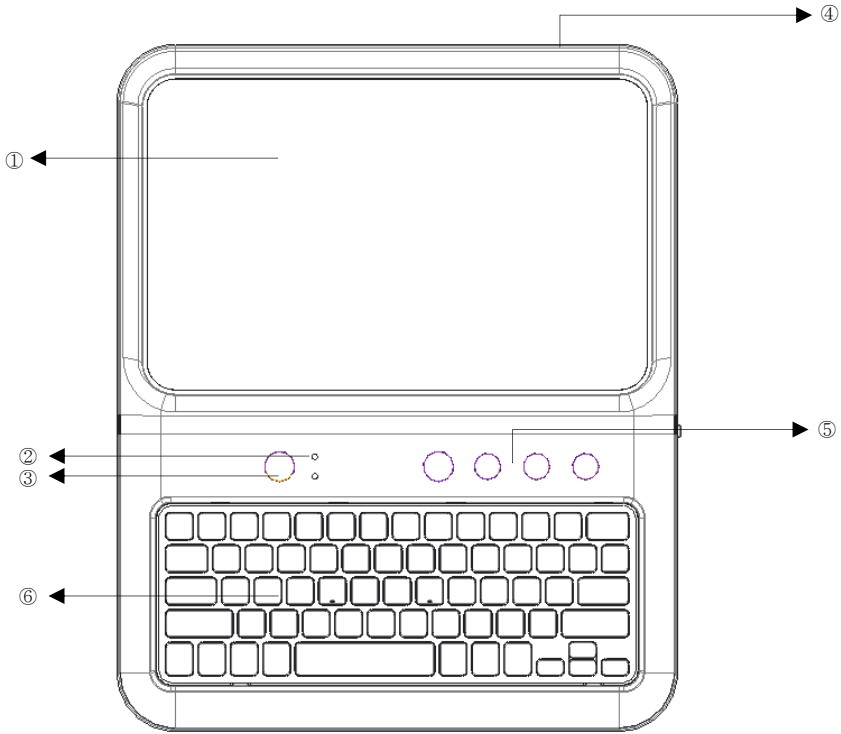



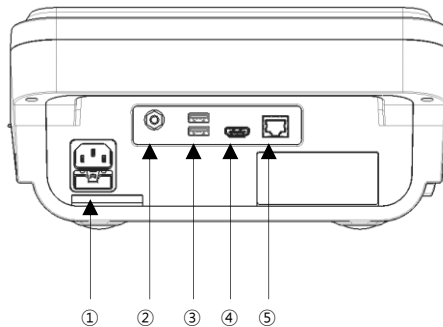

① LCD / ② LED / ③ Power Switch / ④ Handle / ⑤ Function Keys / ⑥ Keyboard (Option)

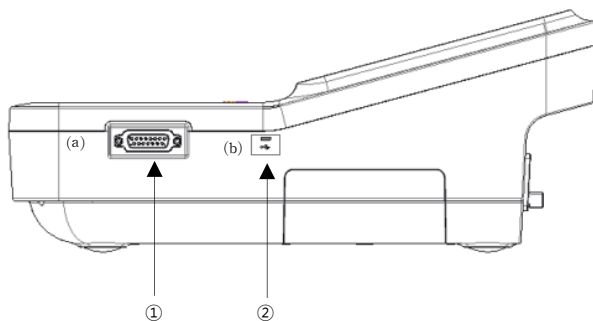

① AC Power Terminal / ② Ground Connection Terminal / ③ USB Port / ④ HDMI Port / ⑤ LAN Port (RJ45)



- ① Patient cable connection port
- ② USB Port (SpiroHandle Port)

Control Panel	Status Display	
		<p>AUTO.</p> <p>1. Short Press Perform the operation that is the most frequently performed in the saving, transmission and printing of data in the ECG diagnosis test with one key</p> <p>2. Long Press (more than 3 seconds) Acquire data for 10 seconds or for a long time (1 minute, 3 minutes, 5 minutes, or 10 minutes), process signals, and print them in the selected form</p>
		<p>RHYTHM.</p> <p>Output the wave of ECG on a real time basis or print it in Report size</p>
		<p>COPY.</p> <p>Print entered data after processing the signs in the same or modified form</p>
		<p>ESC.</p> <p>Perform the cancellation of the order for performance and conversion to previous mode when entering on main menu</p>

Trouble Shooting

when printing to the printer, if nothing is printed or the print is faint:

In this case, the printer's cover is not completely covered. Please use after covering the cover well.

When using battery power, three consecutive buzzers sound and the following message appears on the screen:

In this case, the battery power is almost depleted. Connect AC power before use.

Specification

ECG	
ECG Leads	Simultaneous 12 channel ECG and acquisition
Recording Channel	3CH+3RHY, 3CH+1RH, 6CH+1RH, 12CH, 6CH+ST map 1CH Long Time (1min, 3min, 5min, 10min, 20min, 30min) and Special Beat Report (Text, Guide, Vector, ST map)
Gain	2.5, 5, 10, 20, Auto (I~aVF: 10, V1~V6: 5) mm/mV
Printing Speed	5, 12.5, 25, 50, 100 mm/sec
Sampling Rate	Analysis Sampling Rate - 500Hz Digital Sampling Rate - 8,000Hz
Filters	AC (50/60 Hz, -20dB or better), Muscle (25~35Hz, -3dB or better), Baseline Drift (0.05Hz, 0.1Hz, 0.2Hz, -3dB or better), Low Pass Filter(off, 40Hz, 100Hz, 150Hz)
Patient Data	ID, Name, Birthday, Age, Gender, Height, Weight, Race, Smoke, Department, Room No., Study Desc., Accession No., Referring Physician
Basic Measurement	Heart Rate (30~300bpm, ± 3 bpm), PR/RR Int, QRS Dur, QT/QTc Int, P-R-T axis, SV1/RV5/R+S Amp
Electrical	Internal Noise : 20uV(p-p)max Input Impedance : $\geq 50M\Omega$ Input Voltage Range : ± 5 mV CMRR : > 105 dB DC Offset Voltage : $\geq \pm 400$ mV Patient Leakage Current : < 10 uA Frequency Response : 0.05~200 with in -3 dB Isolated, Defibrillation and ESU Protected
Signal Quality Control	Pacemaker Pulse Detection Lead Fault Detection, Signal Saturation Detection
Spiro	
Measuring Values	FVC : FVC, FEV1, FEV1/FVC, FEF 0.2-1.2L, FEF 25-75%, FEF 75-85%, PEF, FEF 25%, FEF 50%, FEF 75%, FIVC, FEV6, PEFT, FET 100%, Error Code, Extrapolation volume COPD : FEV1, FEV6, FEV1/FEV6, LFI, COPD Classification SVC : SVC, TV, ERV, IRV, EC

	MVV : MVV, FB, TV
Presentation	Flow Volume Loop Volume Time Graph Measurement Values Table
Measuring Range	Flow: 0 to ± 14 L/s Volume: 0 to ± 12 L
Measuring Method	Differential Pressure Method
Prediction Equation	Morris-Polgar, Knudson-ITS, ECCS-Quanjer, Korea CJK, Pereira
Sample Rate	200 samples/sec
Flow Impedance	< 0.2 mbar s/L at 12 L/s
Measuring Accuracy	Complies with ISO 26782, ISO 23747
Common	
Data Storage	Internal Storage for 500 Data : Built- in Memory
Display	10.1" (8") Color TFT Wide Display (1024 x 600), 12 Channels Preview ECG Wave
User Interface	Touch Screen (Alphanumeric and Symbol Available), Function Keys, Keyboard (Option)
Printer Resolution	Thermal Print Head, Z-fold Paper Report Paper - A4 : 210mm (8.3") x 300mm (11.8") - Letter : 215mm (8.5") x 280mm (11") Paper Size - A4 : 210mm x 150mm (half A4) - Letter : 215mm x 140mm (half Letter) Resolution - Vertical : 8dot/mm - Horizontal : 16dot/mm (0.125mm pitch)
Line Power	Input : 100~240 VAC, 50/60Hz, 1.5~0.75A Output : 15 VDC, 4.2 A
Battery Type	Replaceable and Rechargeable Lithium Ion, 10.8V, 6500mA

Battery Capacity		10 hours of normal use or print 350 ECG (12 channel format at 25mm/s and 10mm/mV) or Spiro pages. Battery recharge to full capacity in 3 hours. (The device is turned off)
Communication		LAN, WIFI (Option), USB flash driver, USB barcode scanner
Safety Conformity		Class I, Type CF Applied Parts: ECG Electrodes Type B Applied Parts : Spirometer Handle
Environmental	Operation	Ambient Temperature : 10 to 40°C Relative Humidity : 30 to 85% Atmospheric Pressure : 700 to 1060hPa
	Storage/Ship	Ambient Temperature : -20 to 60°C Relative Humidity : 10 to 95% Atmospheric Pressure : 500 to 1060hPa
Dimensions		Main Body - 286(W) x 350(D) x 140(H) mm (Cardio Q50) - 286(W) x 350(D) x 144(H) mm (Cardio Q70) - Approx. 4.5kg (Max) Spiro Handle - 48(W) x 39(D) x 201(H) mm - Approx. 250g
Standard Accessory		Patient Cable (1EA), Limb Electrodes (1SET), Chest Electrodes (1SET), ECG Chart Paper (1EA), AC Power Cord (1EA), ECG Gel (1EA), Operation Manual (1EA), ECG Diagnosis Guide (1EA)
Options		Rechargeable Battery (1EA) Spiro Handle (1EA), Spiro Diagnosis Guide (1EA), Disposable Mouthpiece (2EA), Nose Clip (1EA), Mouthpiece Adaptor (1EA), Handle Dock (1EA), Disposable Mouthpiece 1 Box (100EA), PFT Filter (100EA), Calibration Syringe[3L] (1EA)
Additional Specification		
Wireless Function (Archer T2U AC600)	Wireless Standard : IEEE 802.11ac, IEEE 802.11a IEEE 802.11n, IEEE 802.11g, IEEE 802.11b Frequency: 5 GHz, 2.4 GHz Signal Speed (5 GHz) - 11ac : Max 433Mbps (Dynamic) - 11n : Max 150Mbps (Dynamic)	

	<ul style="list-style-type: none"> - 11a : Max 54Mbps (Dynamic) <p>Signal Speed (2.4 GHz)</p> <ul style="list-style-type: none"> - 11n : Max 150Mbps (Dynamic) - 11g : Max 54Mbps (Dynamic) - 11b : Max 11Mbps (Dynamic) <p>Receive Sensitivity (5 GHz)</p> <ul style="list-style-type: none"> - 11a 6Mbps : -94dBm - 11a 54Mbps : -78dBm - 11n HT20 MCS0 : -94dBm - 11n HT20 MCS7 : -77dBm - 11n HT40 MCS0 : -92dBm - 11n HT40 MCS7 : -74dBm - 11ac VHT80 MCS0 : -89dBm - 11ac VHT80 MCS9 : -64dBm <p>Receive Sensitivity (2.4 GHz)</p> <ul style="list-style-type: none"> - 11b 1Mbps : -99dBm - 11b 11Mbps : -91dBm - 11g 6Mbps : -94dBm - 11g 54Mbps : -77dBm - 11n HT20 MCS0 : -95dBm - 11n HT20 MCS7 : -76dBm - 11n HT40 MCS0 : -92dBm - 11n HT40 MCS7 : -73dBm <p>Transmission Strength : <20dBm (EIRP)</p> <p>Wireless Mode : Ad-Hoc / Infrastructure Mode</p> <p>Wireless Security : WEP, WPA/WPA2, WPA-PSK/WPA2-PSK</p> <p>Modulation Technology</p> <ul style="list-style-type: none"> - DBPSK, DQPSK, CCK, OFDM, 16-QAM, 64-QAM
--	---

Warranty Period	1 year from date of purchase (2 years in USA)
------------------------	---

Request for Instructions for use in paper form

Electronic form instructions are now being widely used to reduce paper consumption, increase accessibility for users. Instructions for use of the device are supplied in electronic form instead of in paper form. Instructions for use in paper form can be requested at no additional cost within 7 calendar days from our distributors by mail.



Headquarters & International Sales & Service

Bionet Co., Ltd.:

5F, 61 Digital-ro 31 gil, Guro-gu, SEOUL
08375, REPUBLIC OF KOREA

Tel: +82-2-6300-6410 / Fax: +82-2-6499-7789 / E-mail: sales@ebionet.com

Website: www.ebionet.com

U.S.A Sales & Service Representative

Bionet America, Inc.:

2691, Dow Ave, Suite B
Tustin, CA92780 U.S.A.

Toll Free: 1-877-924-6638 / Fax: 1-714-734-1761 / E-mail: support@bionetus.com

Website: www.bionetus.com

European Sales & Service Representative

Bionet Europe GmbH

2Li Bessemerstr. 51,
D-12103 Berlin, Germany

Tel: +49-30-240-374-52 / E-mail: bionetEU@ebionet.com

Website: www.ebionet.com

Bionet Co., Ltd

Model Name: Cardio Q50 / Cardio Q70